

匯統國際股份有限公司

Huey Tung International Co., Ltd.

產品規格書 Specification

[Model : HT-01293 / 2015.05.12 Version]



Cara Audio Corporation

No.69, Lane 762, Dingzhong Road, Sanmin District, Kaohsiung City, Taiwan, ROC.

Tel: 886-7-310 5786 / Fax: 886-7-310 0783

E-mail: carawang@hueytung.com.tw / <http://www.hueytung.com.tw>

1 Name: Omni-directional Electret Condenser Microphone (Foil Electret Type)

2 TYPE: HT-01293

3 Electrical Specifications:

3.1	Sensitivity Range	-36±2dB RL=2.2KΩ VCC=4.5V (1KHz 0dB=1V/Pa)
3.2	Impedance	Max .2.2KΩ 1KHz (RL=2.2KΩ)
3.3	Frequency	100-10000 Hz
3.4	Current Consumption	Max.0.5mA
3.5	Operation Voltage Range	1.0V-10V
3.6	Max. Sound Pressure Level	120dB S.P.L
3.7	S/N Ratio	More than 58dB
3.8	Sensitivity Reduction	4.5V-3.0V Sensitivity Variation less than 3dB

3.9 Typical Frequency Response Curve :

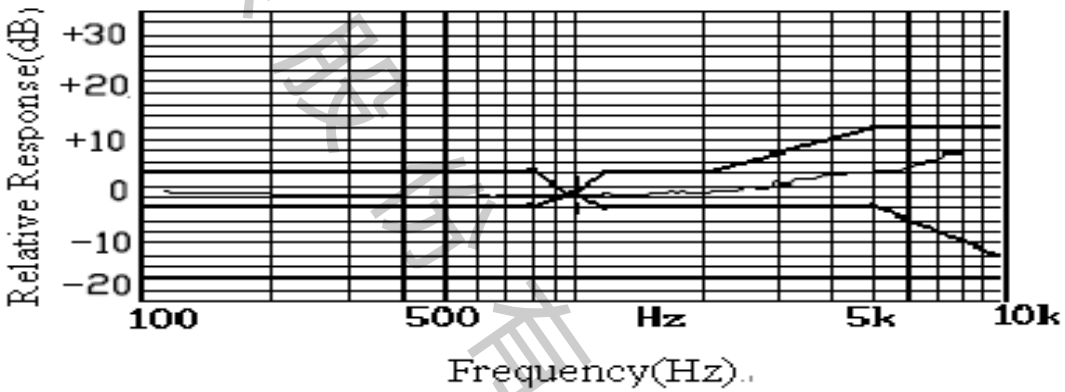

3.10 Schematic Diagram :

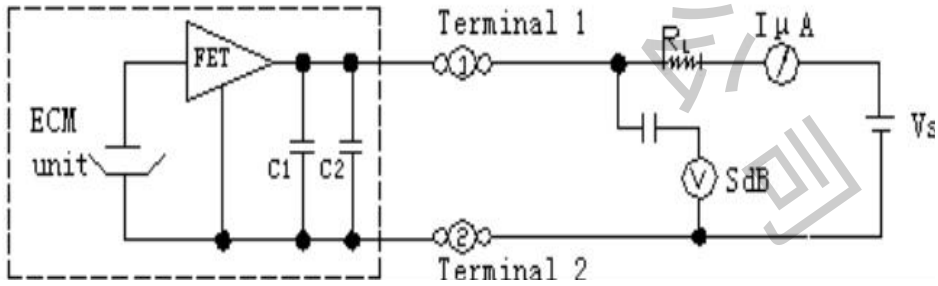

4 Mechanical Specifications :

C
1
=
1
0
P
F

C
2
=
3
3
P
F

版權所有

4.1 Drawing

Item	Part Name	Material	Q'ty	Color	Supplier
1	Filter	Fabric	1	Black	CHINA
2	Case	Aluminum metal alloy	1	White	CHINA
3	Diaphragm	FEP Plated Chromium	1	Bright	Dupont USA
4	Spacer	Polyester Film	1	Red	CHINA
5	Back Plate	Brass Plated Nickel	1	Bright	CHINA
6	Holder	ABS Plastic	1	White	CHINA
7	Metal Ring	Brass Plated	1	Bright	CHINA
8	PCB	CEM-1	1	Blue	CHINA
9	Capacitor	10pF 0402	1	Grey	MURATA
		33pF 0402			
10	FET	TF202.E5	1	Black	CHINA

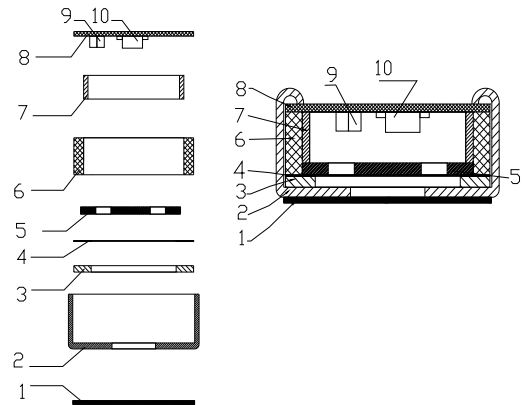

4.2 Dimension (mm):

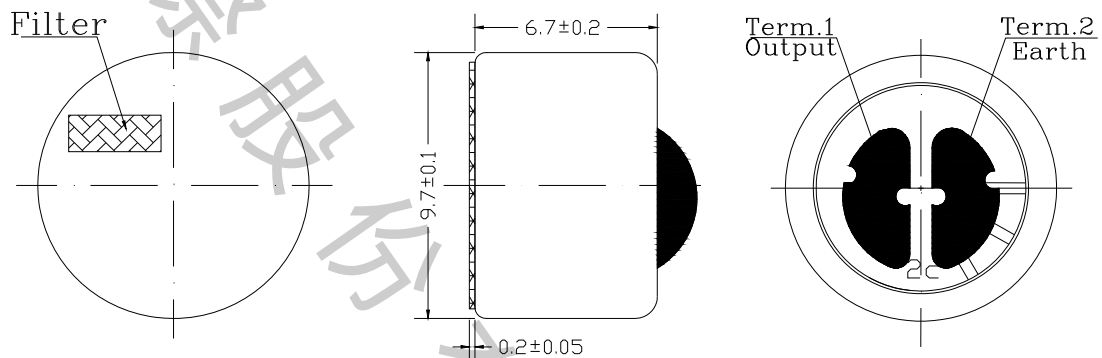

4.3

Weight

0.6g

5. Reliability Tests: After any following tests, the sensitivity of the microphone unit shall not change more than $\pm 3\text{dB}$ from initial value, and shall keep their initial operation and appearance.

5.1	Hi-Temp. Test	The microphone unit must be subjected to $+70^{\circ}\text{C}$ for 48 Hours, and expose to room temperature for 3 Hours.
5.2	Low-Temp. Test	The microphone unit must be subjected to -25°C for 48 Hours, and expose to room temperature for 3 Hours.
5.3	Humi.&Heat Tes	The microphone unit must be subjected to $+40^{\circ}\text{C}$, 93% RH-for 48 Hours, and expose to room temp for 3 Hours .
5.4	Humidity Shocking Test	The microphone unit must be subjected to following conditions ($+45^{\circ}\text{C}$ 1H-room temp 1H; -10°C 1H-room temp 1H) at 5 cycle, and expose to room temp for 3 Hours.
5.5	Vibration Test	The microphone unit must be subjected to a procedure that after vibrating for two hours from each of the two directions with a frequency of 10-55Hz and a 1.52mm-high amplitude.
5.6	Dropping Test	The microphone unit must be subjected to a procedure that after dropping to a slippery marble floor for 5 times from a 1-meter-high without package.

6

Environmental Condition:

6.1	Storage condition	$-20^{\circ}\text{C} \sim +60^{\circ}\text{C}$ R.H. less than 45%~75%
6.2	Operation condition	$-10^{\circ}\text{C} \sim +45^{\circ}\text{C}$ R.H. less than 85%

	6.3	Arbitration condition	Temperature : 20°C±1°C Relative humidity : 63%~67% Air pressure : 86~106Kpa
7	Notices:		
	7.1	All the soldering procedures upon microphones must be completed in a metallic device, the temperature of the soldering iron must be limited as 310°C± 20°C .	
	7.2	Operators, the solder fixtures and the soldering irons must be statically grounded under each soldering process.	

國
 際
 股
 份
 有
 限
 公
 司
 版
 權
 所
 有